

Manual Threshold-free door

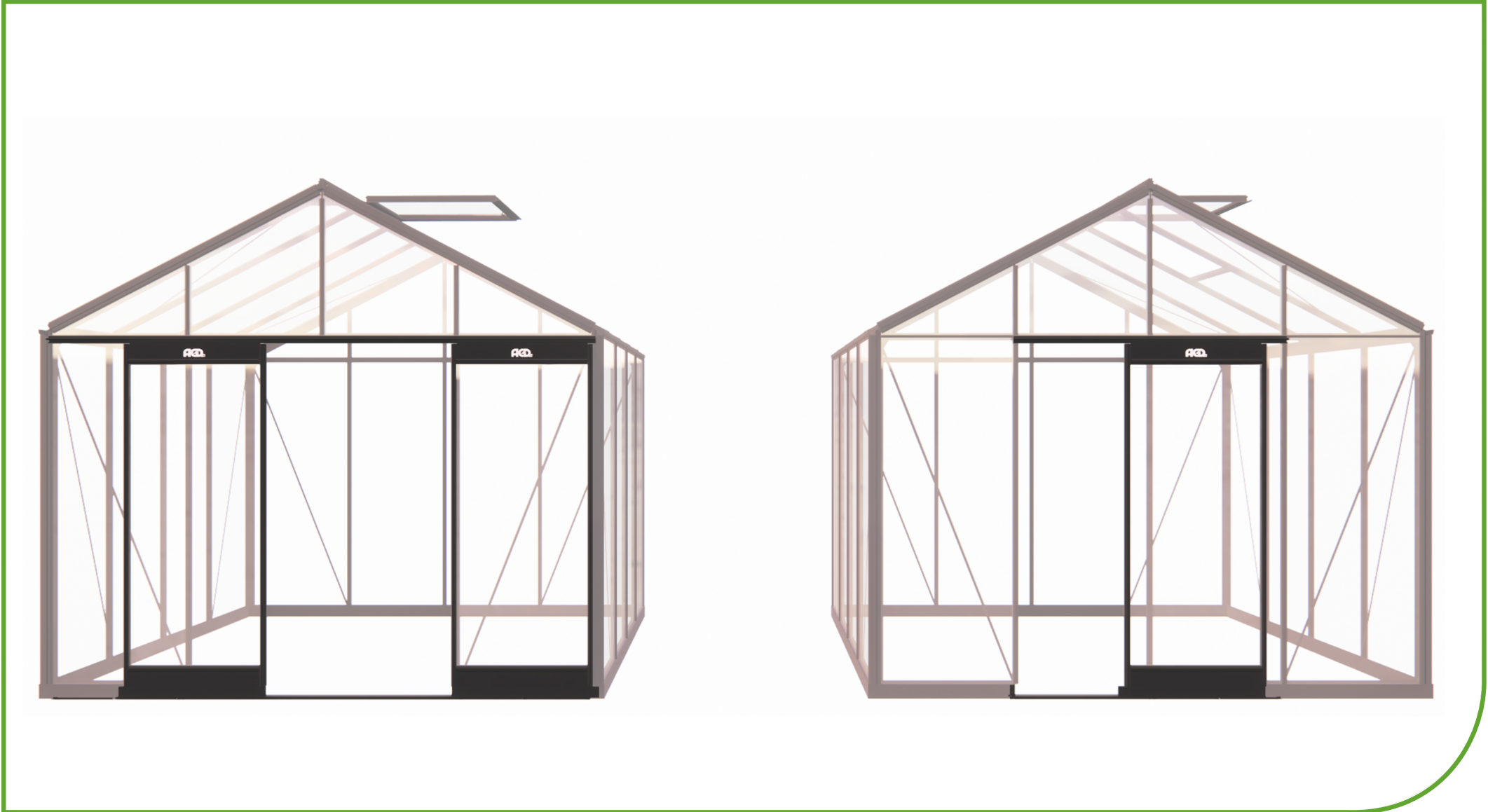

Stap 1:

Koppel de fundering los waar de drempelloze deur komt na het plaatsen van de volledige serre.

Etape 1:

Enlevez l'embase où se trouvera la porte sans embase après avoir installé l'ensemble de la serre

Step 1:

Disconnect the base where the threshold-free door will be after installing the entire greenhouse.

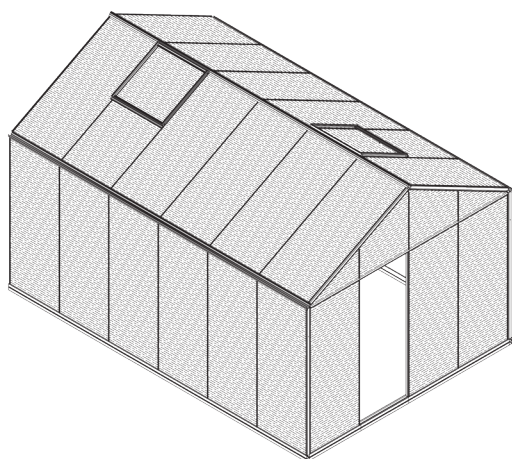

Single threshold-free door

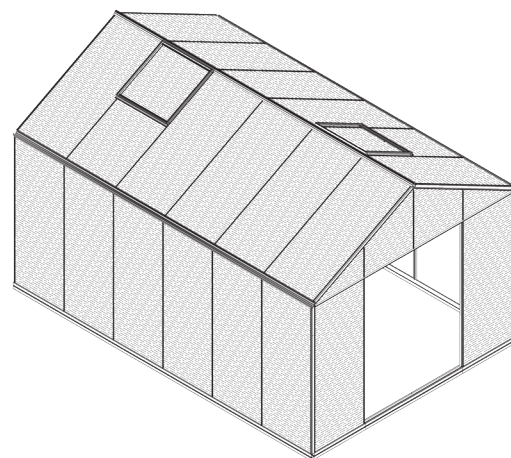
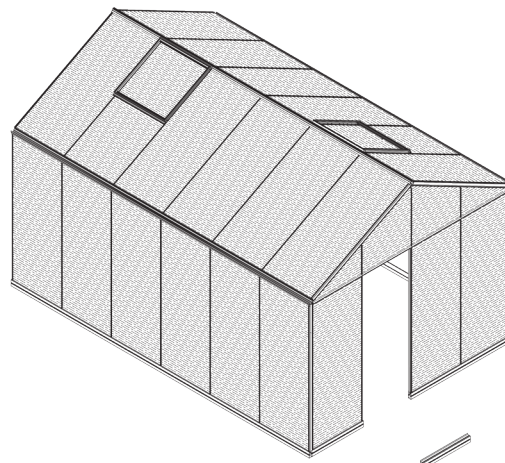

Double threshold-free door

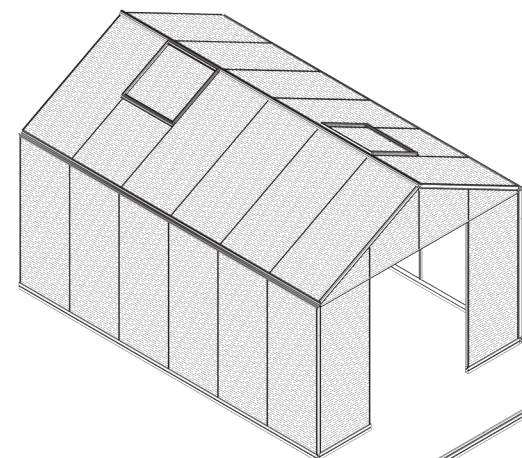

- Stap 2:** Montage van enkele drempelloze deur.
Etape 2: Installation d'une simple porte sans embase.
Step 2: Installation of single threshold-free door.

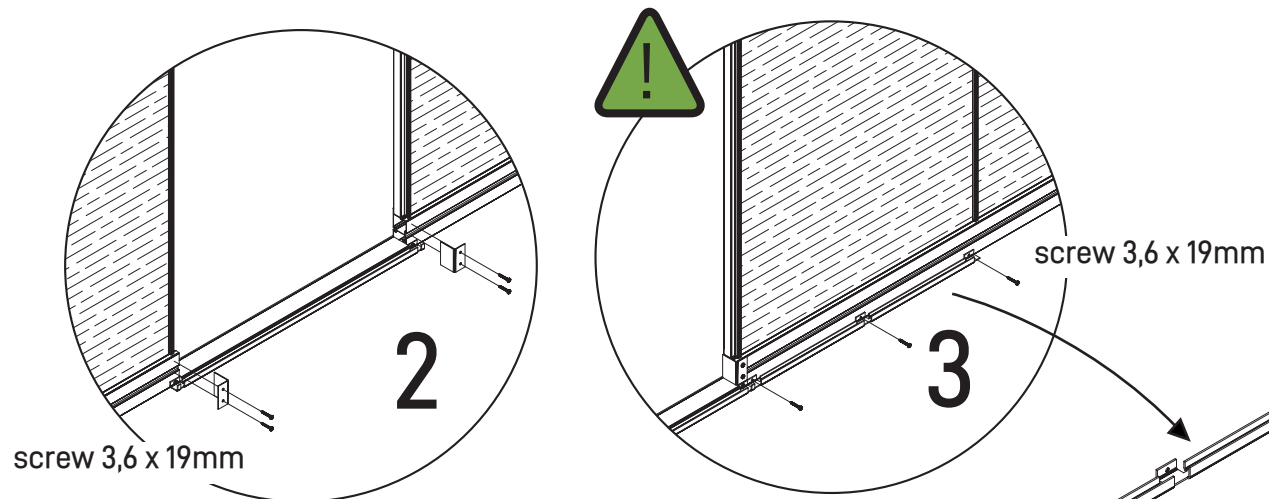
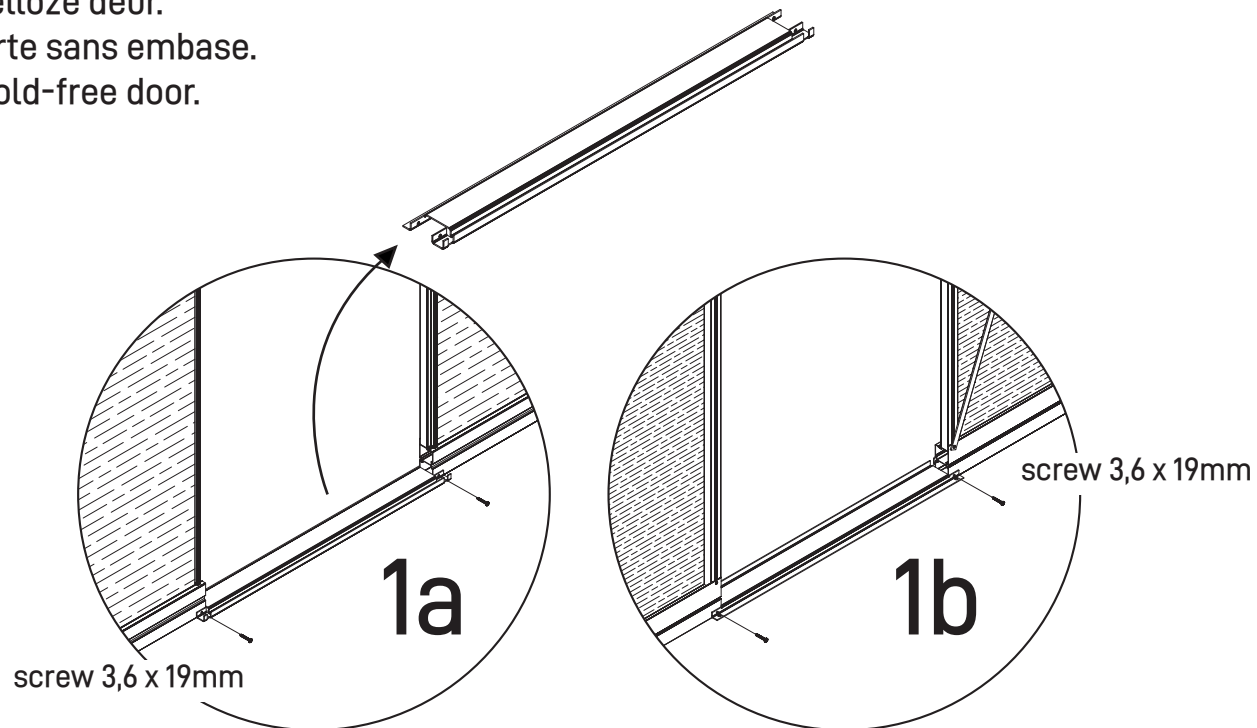
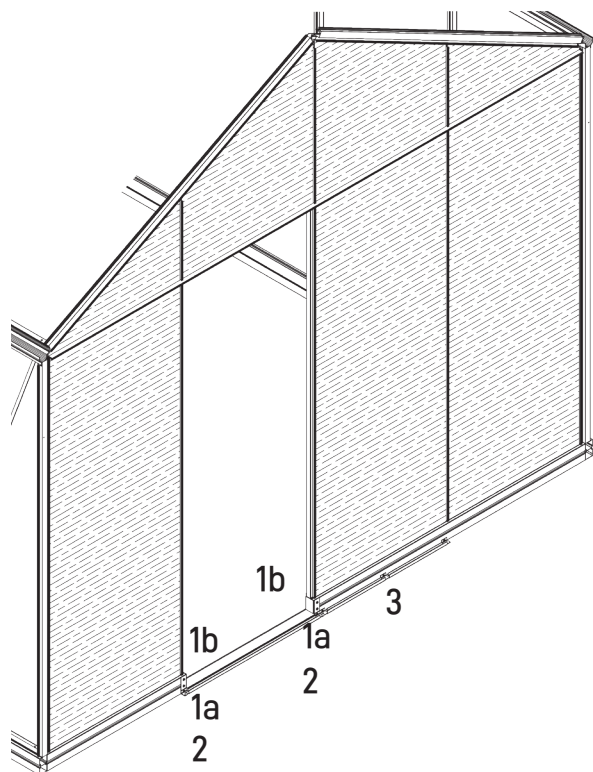

met hordeur, detail 3 uitvoeren aan beide kanten van de deuropening.

Avec porte moustiquaire, exécuter le détail 3 des deux côtés de la porte.

In case of screendoor, perform detail 3 on both sides of the doorway.

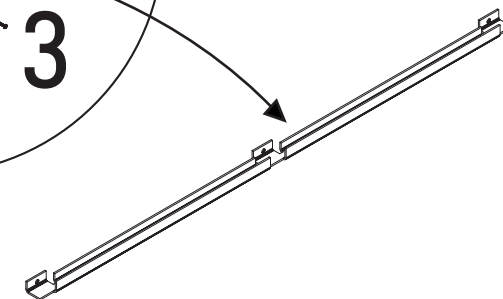

Stap 3: Bevestigen van ankers.

Etape 3: Fixation des ancrs.

Step 3: Fixing the anchors.

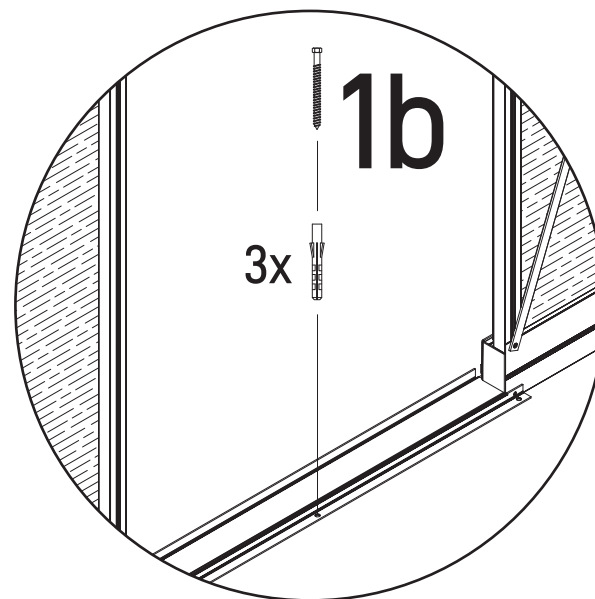
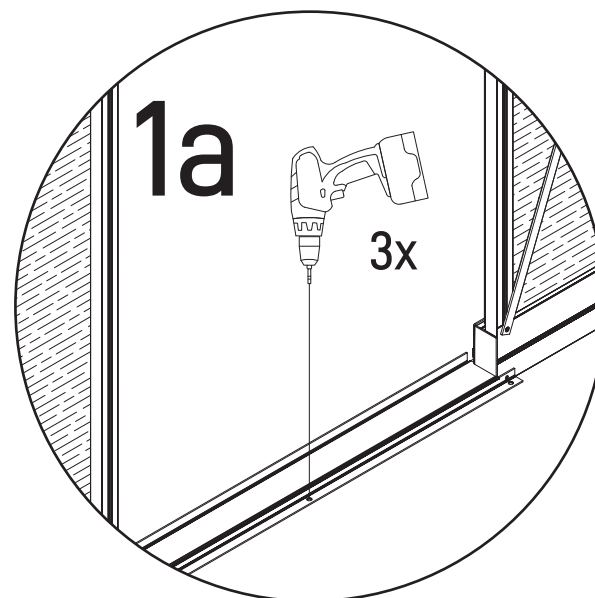
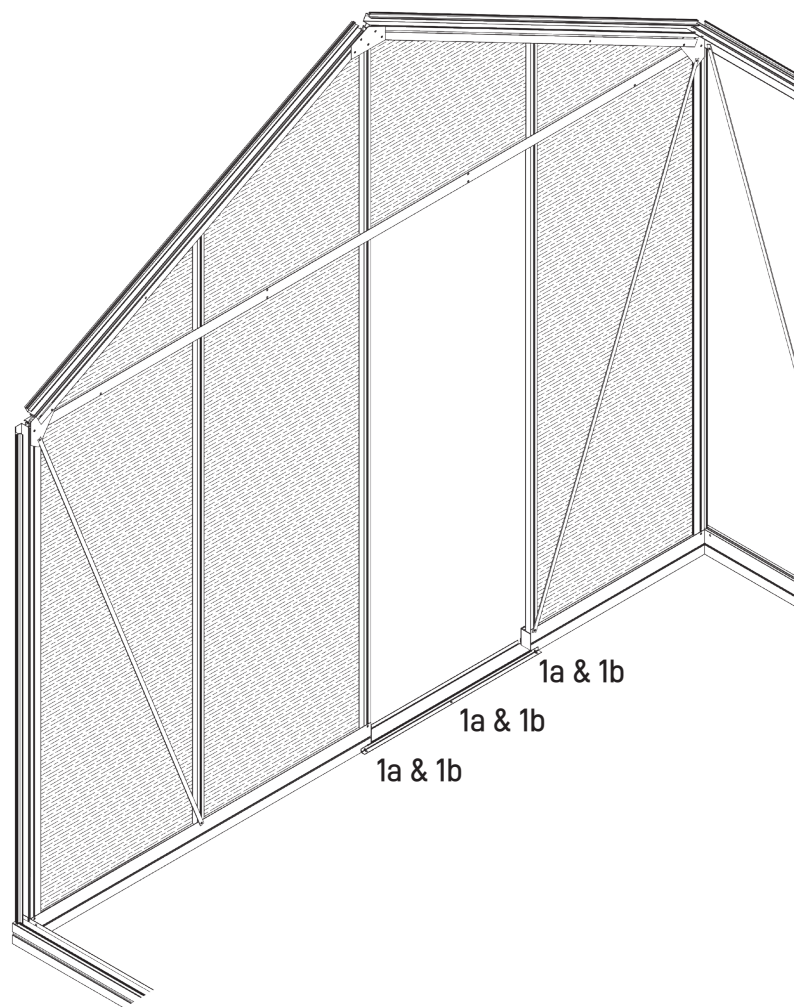

Stap 2: Montage van dubbele drempelloze deur.
Etape 2: Montage d'une double porte sans embase.
Step 2: Installation of double threshold-free door.

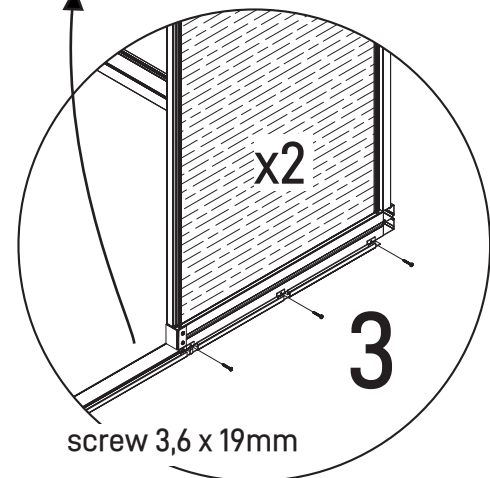
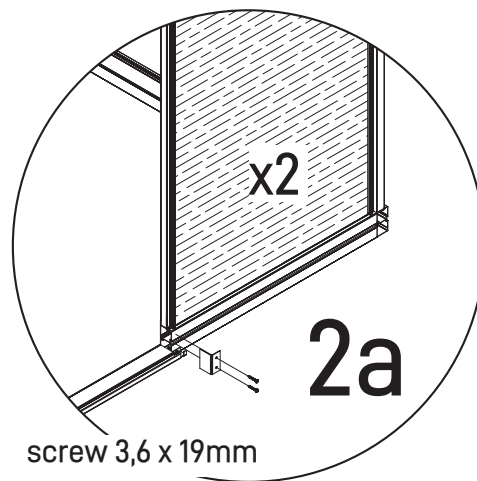
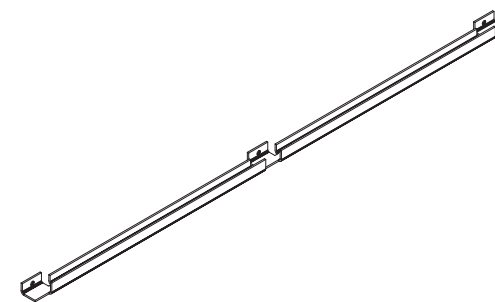
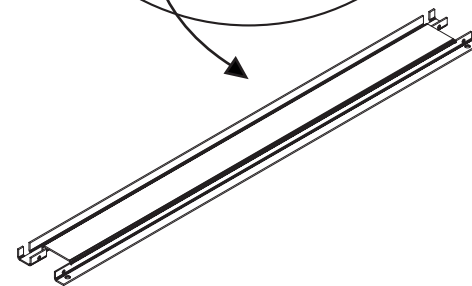
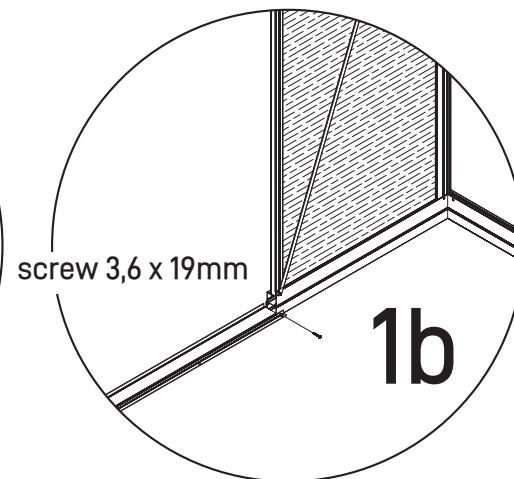
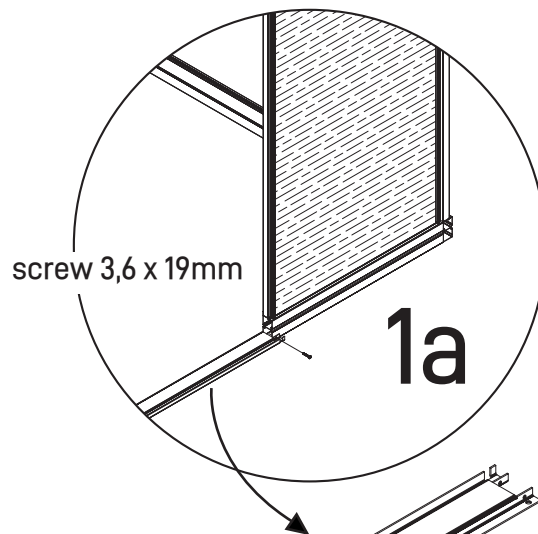
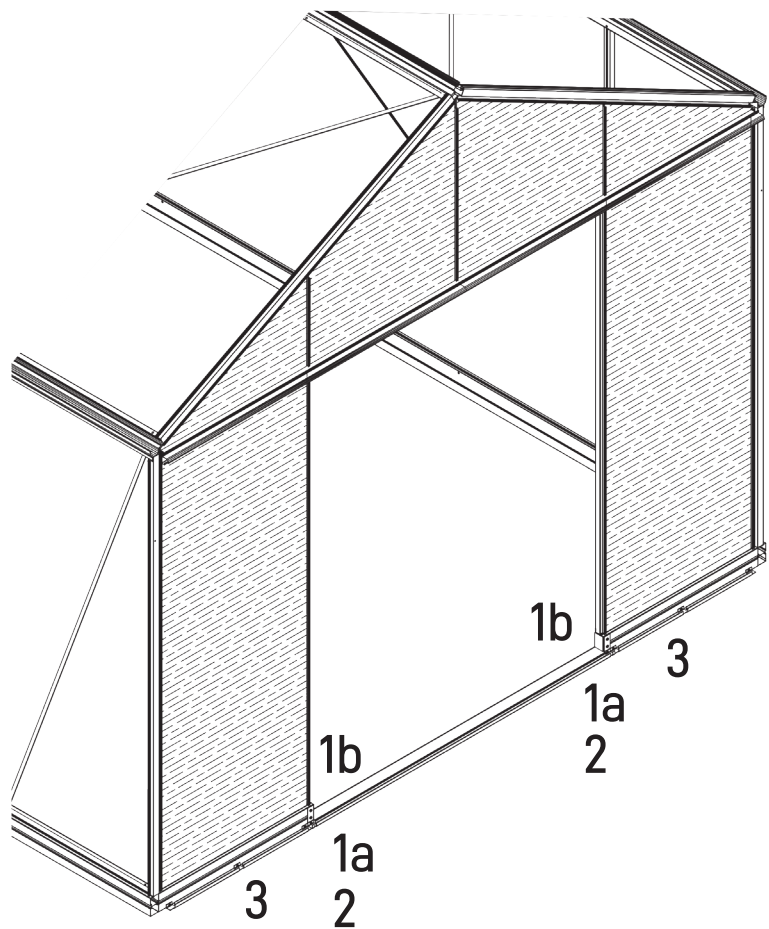

Stap 3: Bevestigen van ankers.

Etap 3: Fixation des ancrés.

Step 3: Fixing the anchors.

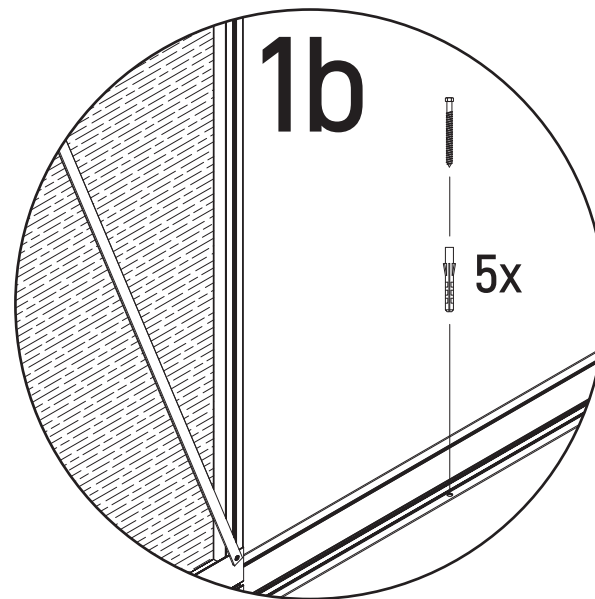
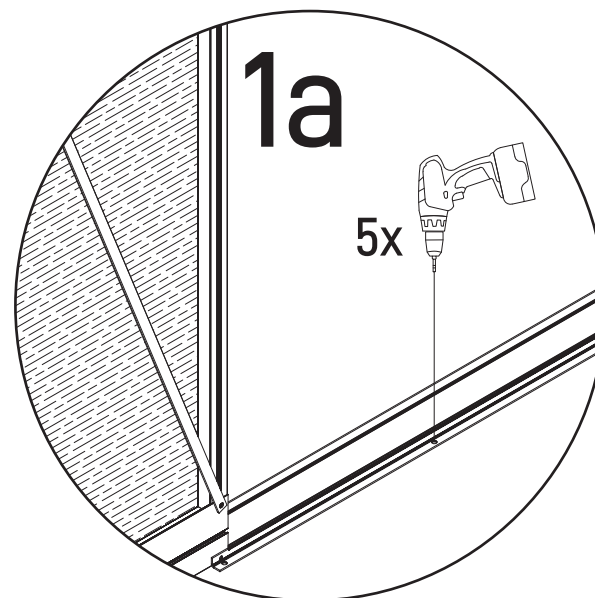
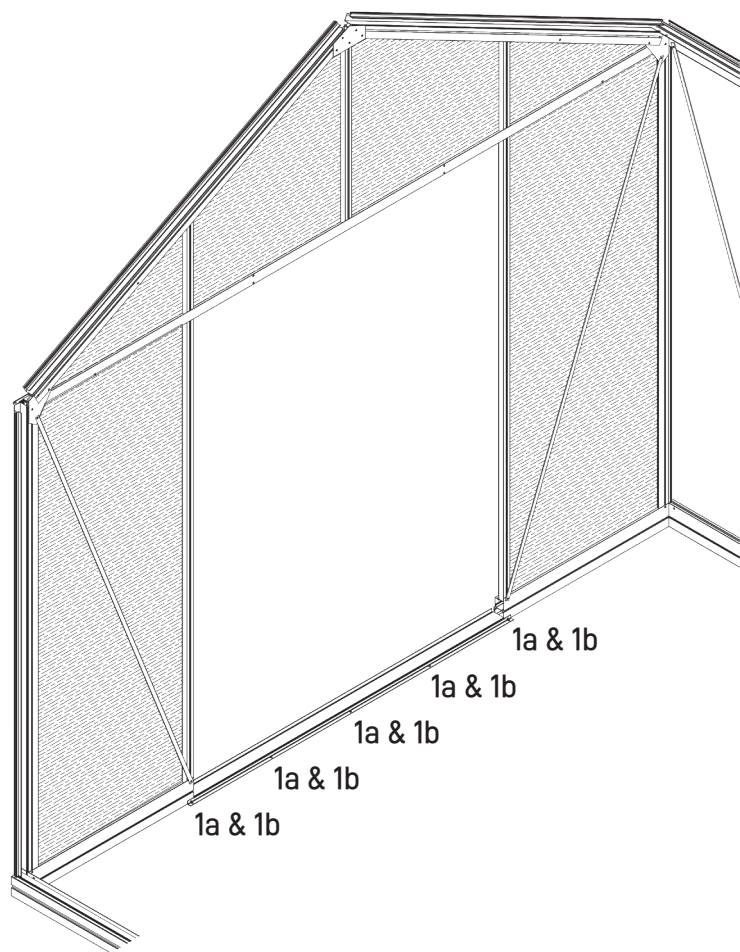

Optioneel: Verankering op volle grond.

Optionnel: Ancrage dans le sol.

Optional: Anchoring in the ground.

Step 1: Breng silicone aan op de onderkant van de drempel.

Etap 1: Appliquer du silicone sur la face inférieure d'embase.

Step 1: Apply silicone to the bottom of the threshold.

Step 2: Bevestig het overige funderingsprofiel aan de drempel.

Etap 2: Fixez le profilé de fondation restant à l'embase.

Step 2: Attach the remaining foundation profile to the threshold.

Step 3: Bevestig de ankerpunten aan de drempel in de voorziene gaten.

Etap 3: Fixez les points d'ancrage en l'embase dans les trous prévus.

Step 3: Attach the anchor points to the threshold in the provided holes.

Single door:
x1 Anchor



Double door:
x3 Anchors

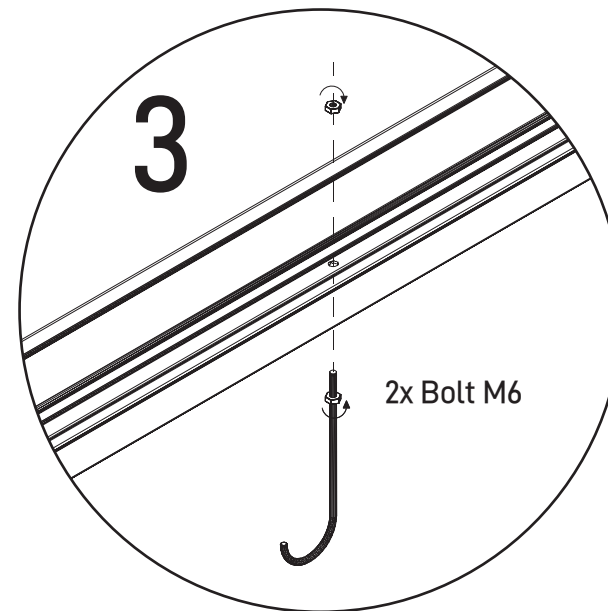
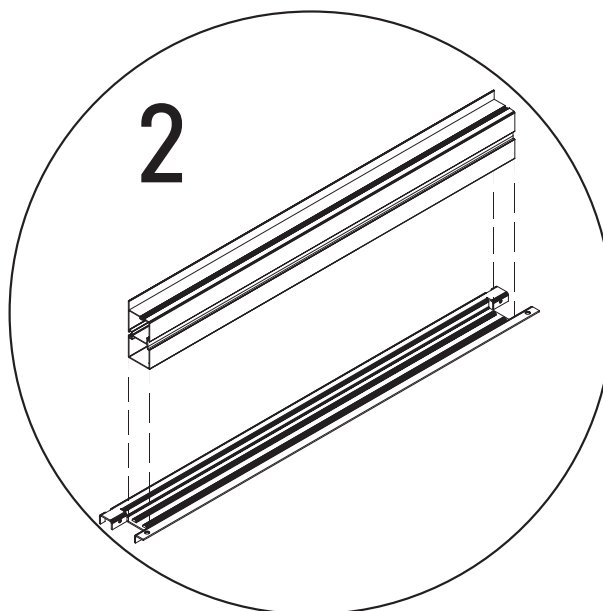
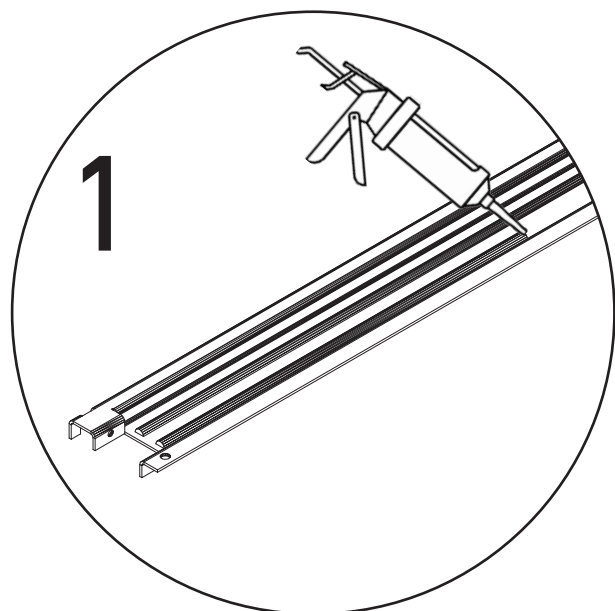
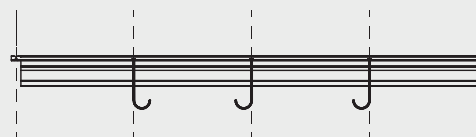

Optioneel: Verankering op volle grond.

Optionnel: Ancrage dans le sol.

Optional: Anchoring in the ground.

- Stap 4:** Maak een sleuf op de plaats van de deur.
Voorzie een min. diepte van de lengte van de ankers.
- Etap 4:** Faire une tranchée à l'emplacement de la porte.
Prévoir une profondeur minimale de la longueur des ancrages.
- Step 4:** Make a trench at the location of the door.
Provide a min.depth of the length of the anchors.

- Stap 6:** Veranker de uiteinden van de fundering met een middenanker.
- Etap 6:** Ancrer les fins de la fondation à l'aide d'un ancrage central.
- Step 6:** Anchor the ends of the foundation with a centre anchor.

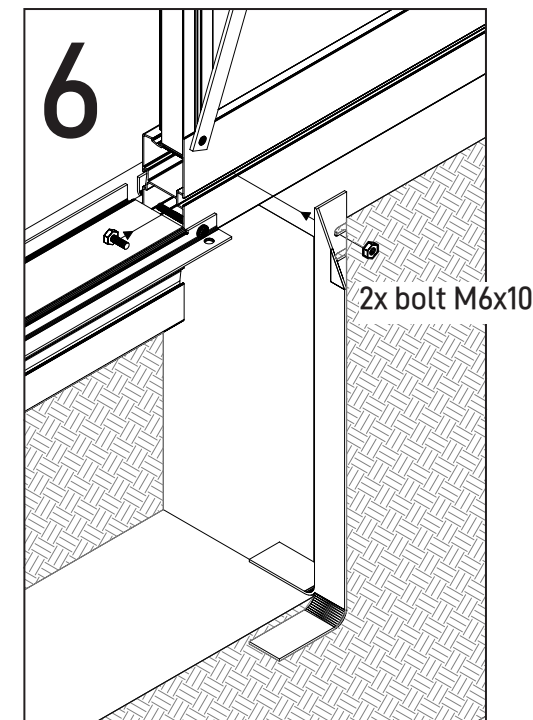
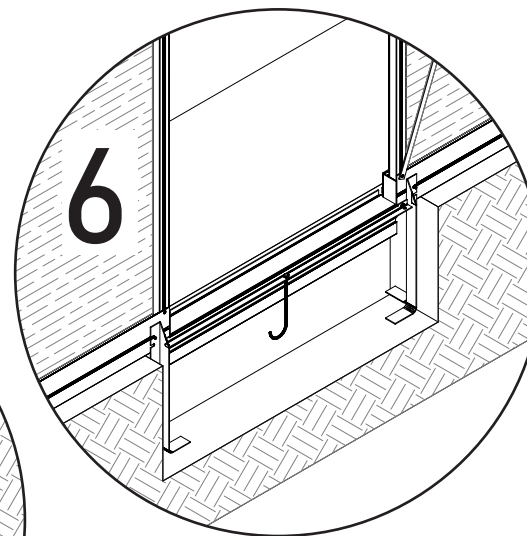
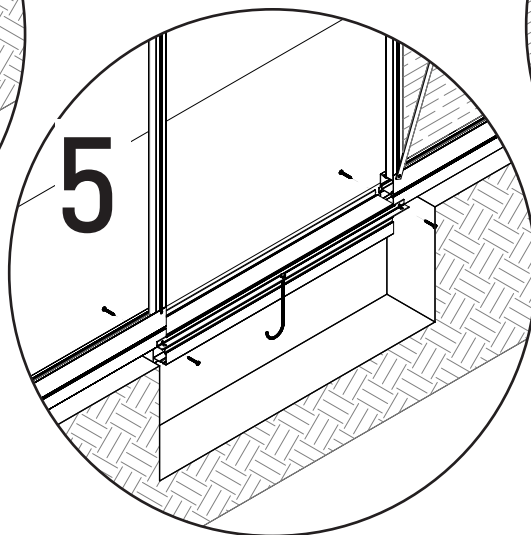
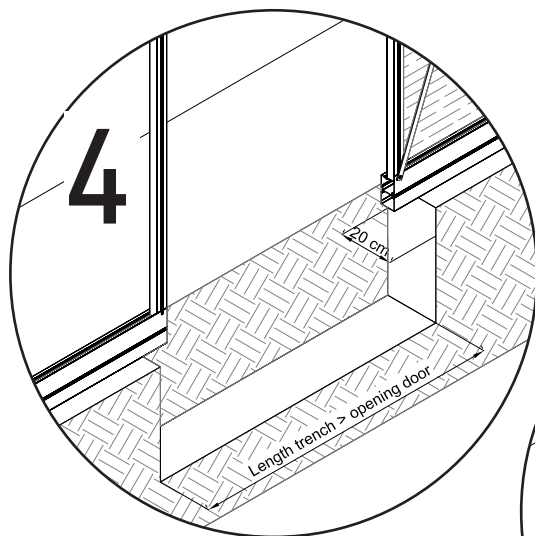

- Stap 5:** bevestig het drempelprofiel terug op zijn plaats.
- Etap 5:** Remettre le profilé sans embase en place.
- Step 5:** Fix the threshold profile back in place.

- Stap 7:** Bevestig de ankers met snelbeton.
- Etap 7:** Remettre le profilé sans embase en place.
- Step 7:** Fixer les ancrages avec du béton rapide.

Step 4: Montage van deur.
Etape 4: Montage de la porte.
Step 4: Installation of door.

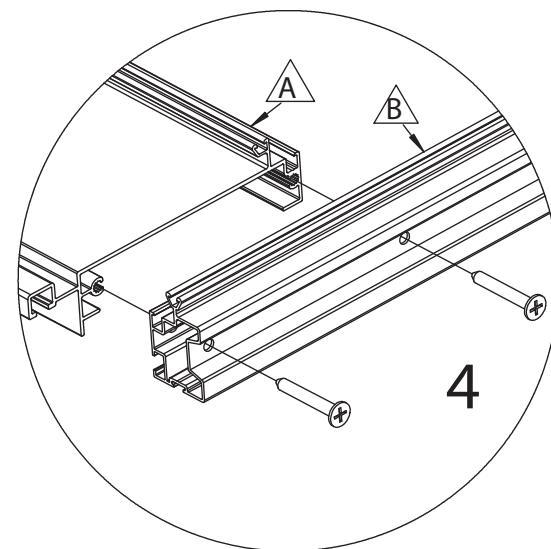
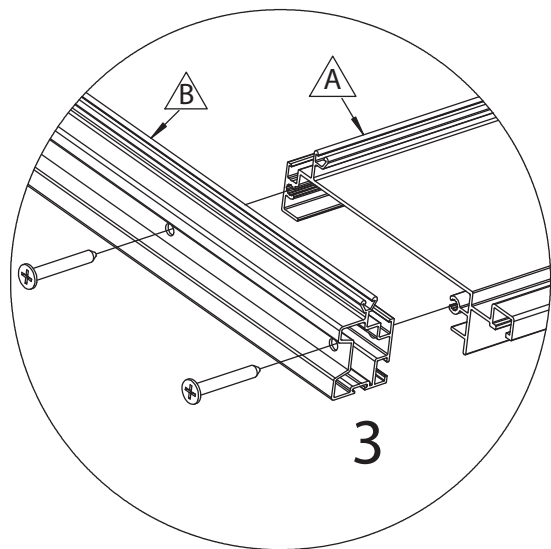
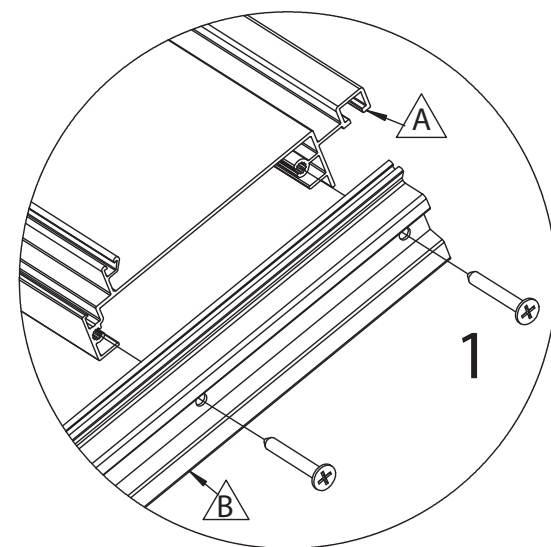
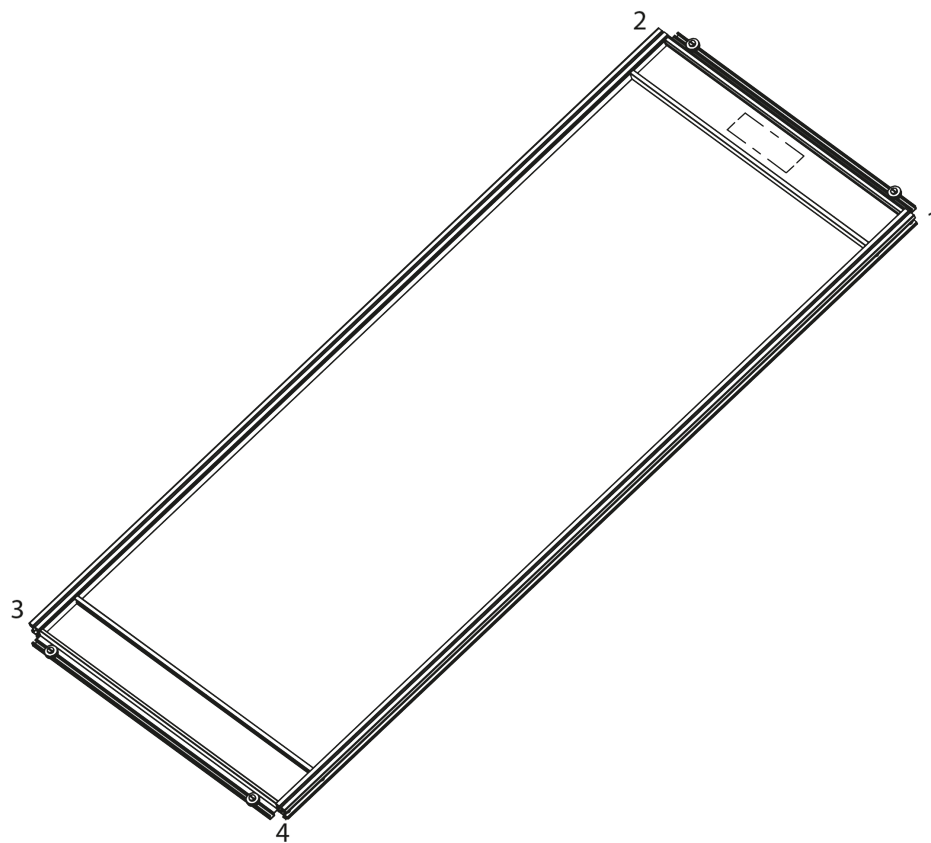
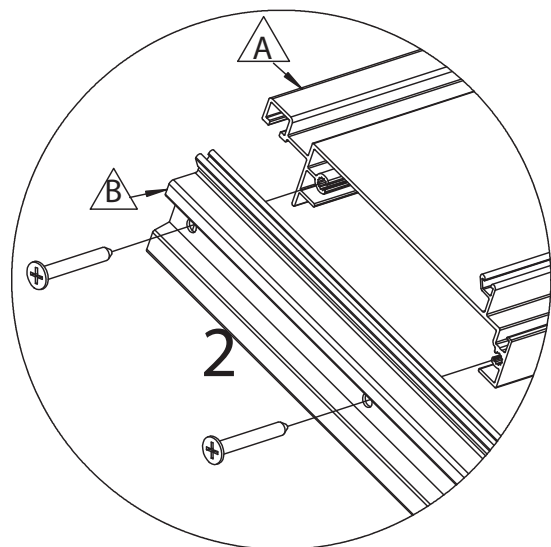

Stap 5: Montage van deur.
Etape 5: Montage de la porte.
Step 5: Installation of door.

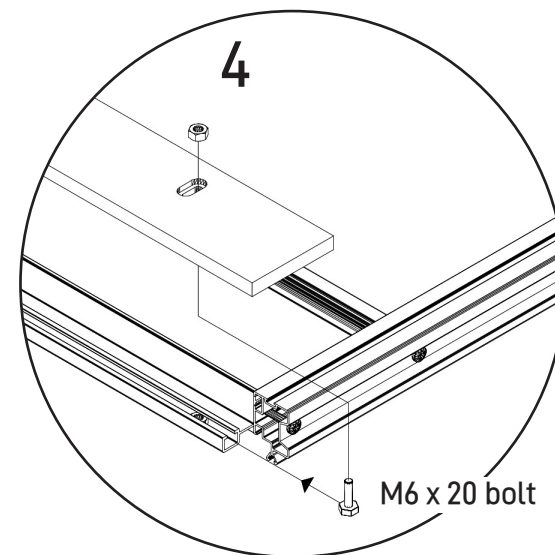
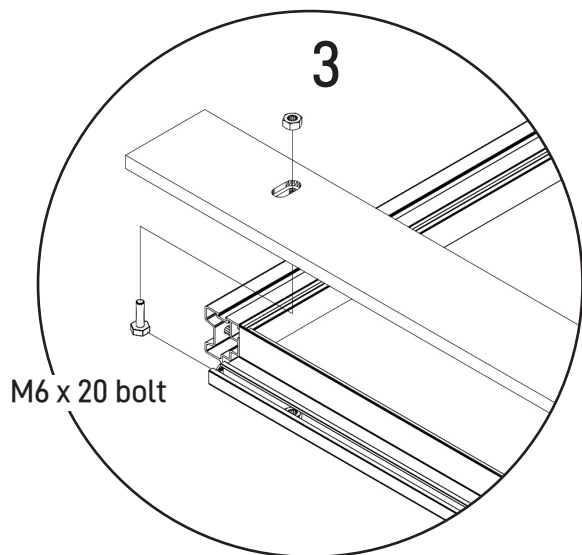
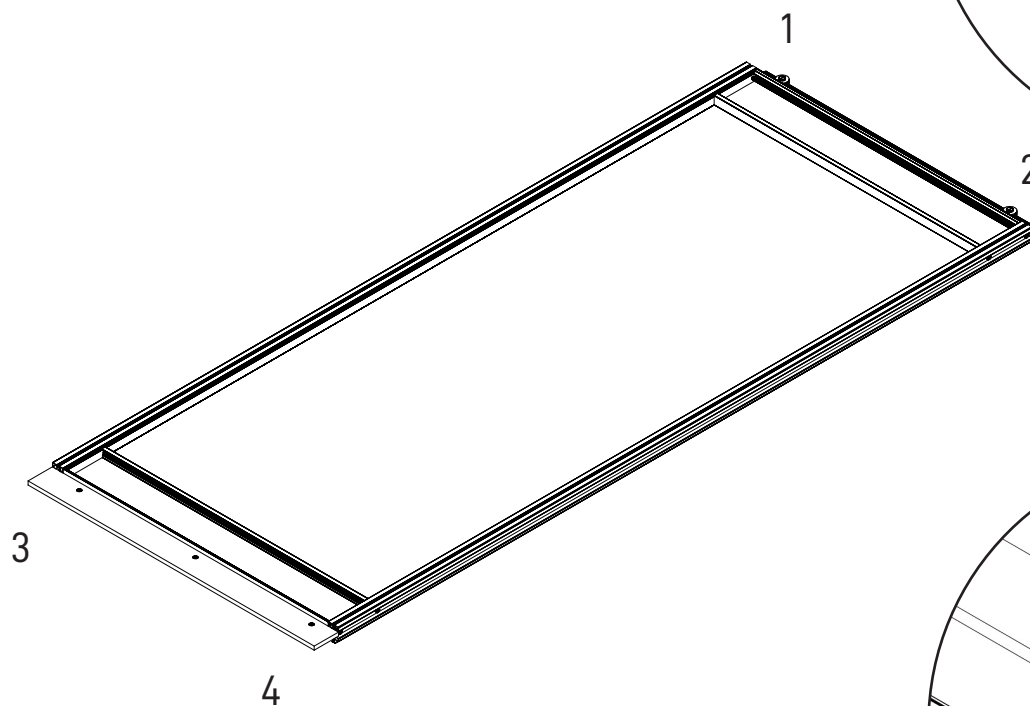
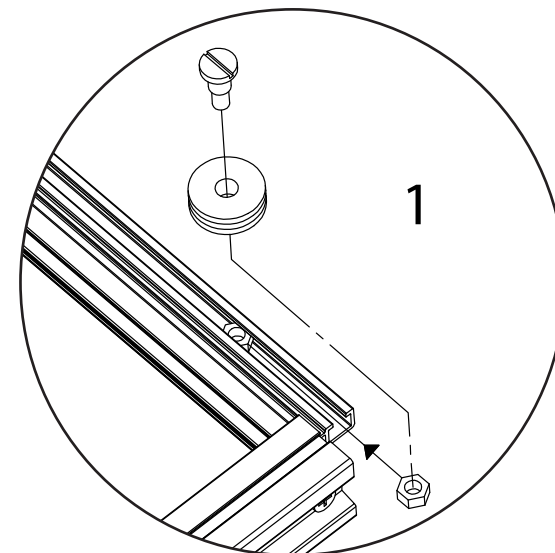
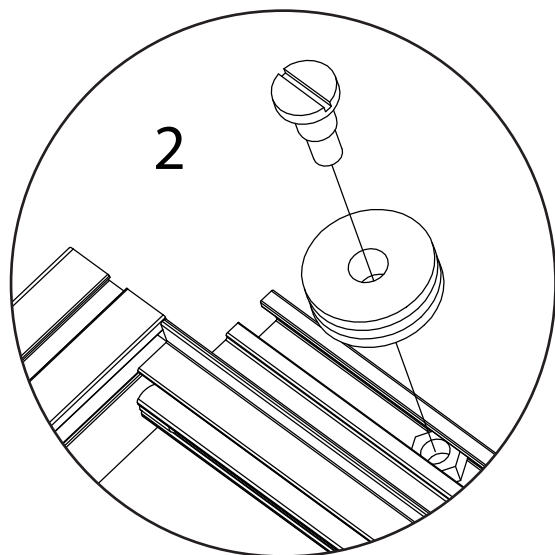

Step 6a: Montage van deur.
Etape 6a: Montage de la porte.
Step 6a: Installation of door.

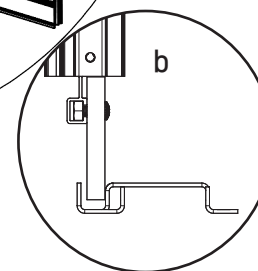
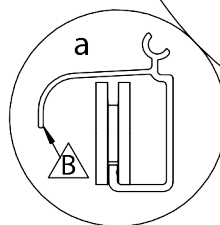
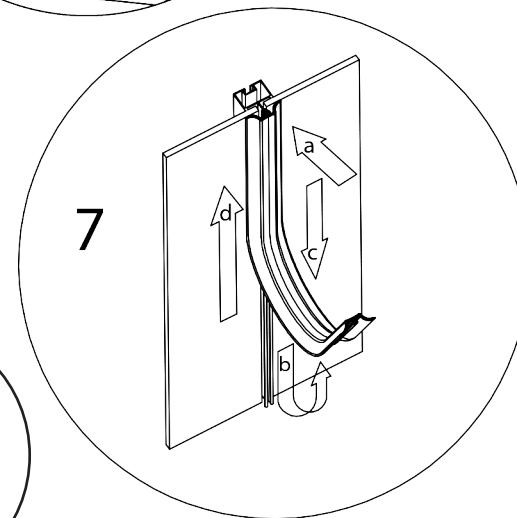
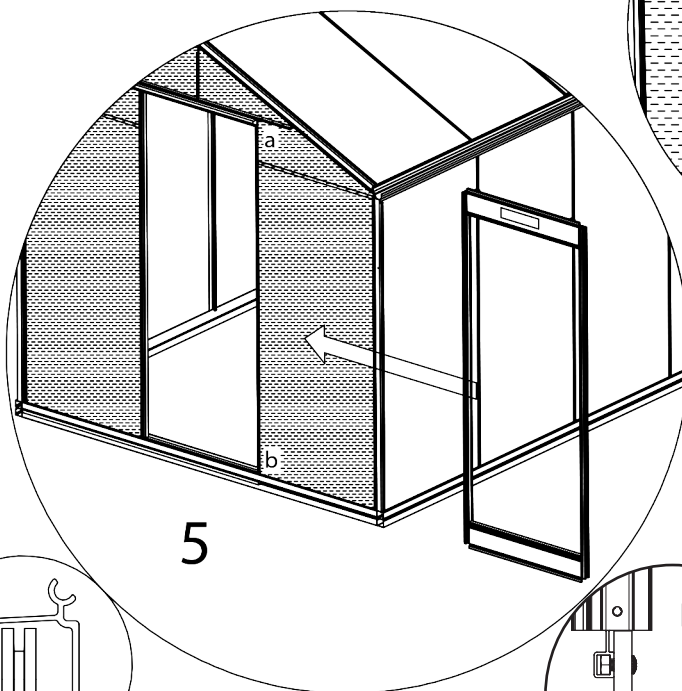
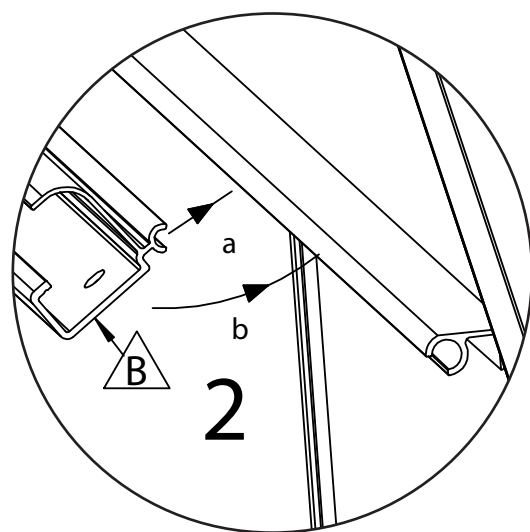
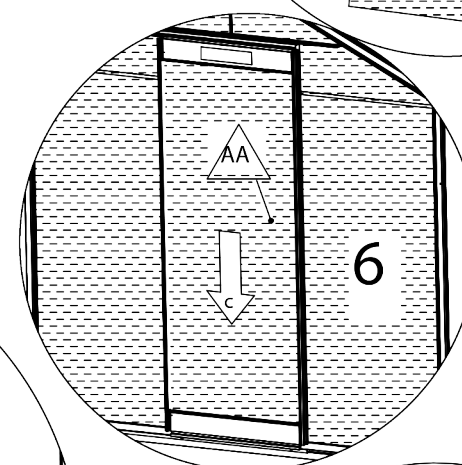
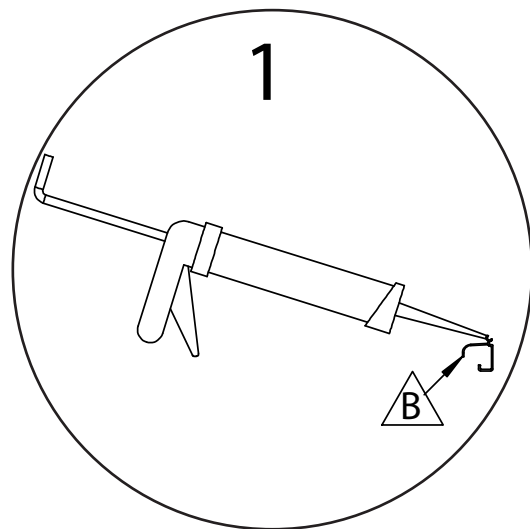
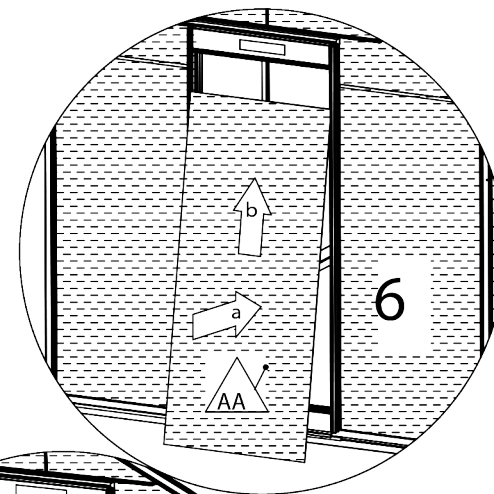
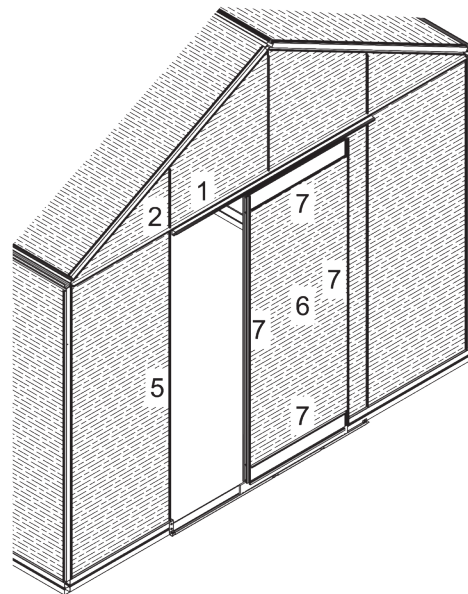

Stap 6b: Montage van deur.
Etape 6b: Montage de la porte.
Step 6b: Installation of door.

